

## Lesson 3. Protecting Against Wind Damage

### Introduction

Wind can tear the roofs from buildings, rip siding from exterior walls, and throw debris through windows. Falling trees can crush roofs and walls.

Of course, hurricanes and tornadoes generate exceptionally destructive winds that can turn buildings into piles of rubble. But high winds can happen anywhere, and strike during many types of storms.

---

**Self-Assessment Question:** How much warning do you have to protect against wind damage?

---

Hurricane watches and warnings usually provide 2 or 3 days' notice to protect your home or business and evacuate, if necessary.

Tornadoes, on the other hand, strike with little warning. Ensuring the safety of your family and employees becomes a top priority.

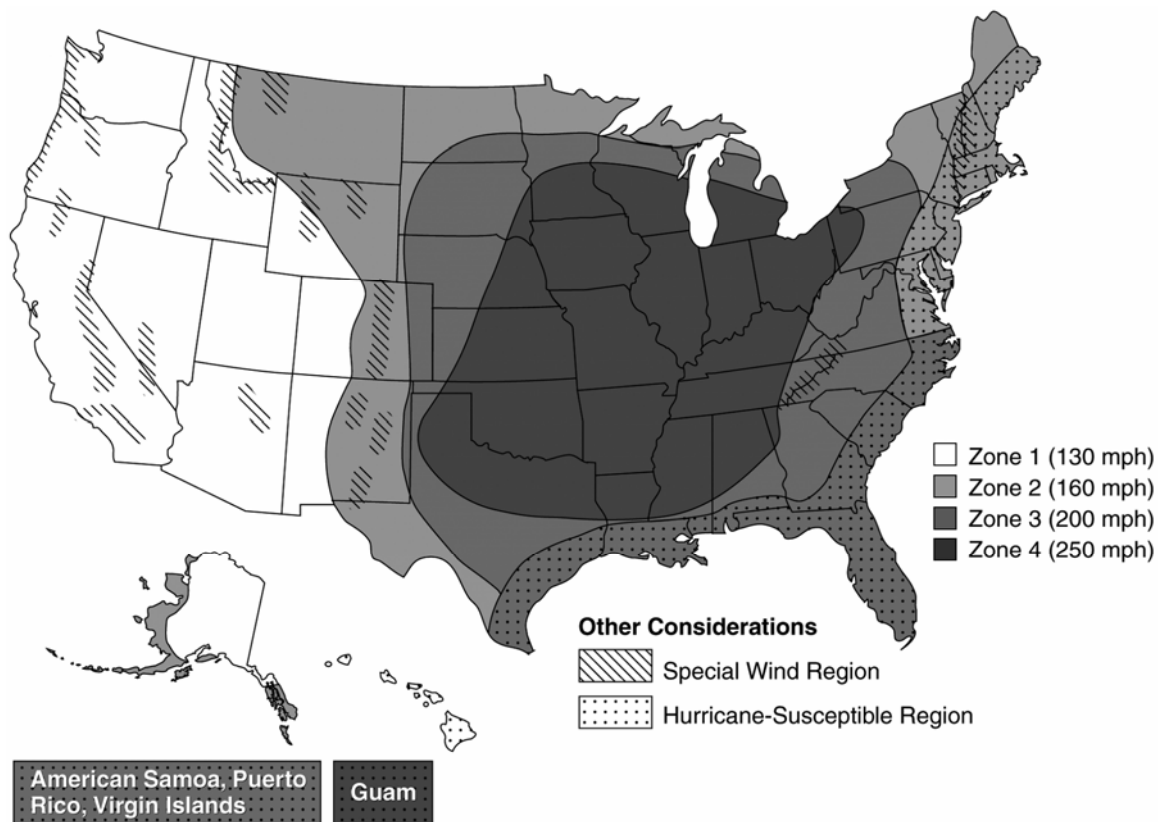

**Figure 1. Map of the United States Showing Maximum Wind Velocities by Zone**  
The map key shows the wind velocity for Zone 1 at 130 mph, Zone 2 shows the wind velocity at 160 mph, Zone 3 shows the wind velocity at 200 mph, and Zone 4 shows the wind velocity at 250 mph. Other considerations shown include the special wind region and the hurricane susceptible region.

## Lesson 3. Protecting Against Wind Damage

### How Great Is Your Risk of Wind Damage?

Your home or place of business may be located near a coastal area that is subject to hurricane-force winds, or you may live in an area at risk for tornadoes.

The map on the preceding page titled “Wind Zones in the United States” shows areas that are susceptible to hurricanes and high winds.

---

#### Self-Assessment Questions:

- In which zone is your house or place of business located?  
    \_\_\_ Zone I     \_\_\_ Zone II     \_\_\_ Zone III     \_\_\_ Zone IV
  - How high is the windspeed you might face? \_\_\_\_\_ mph.
- 

One- and two-story wood frame houses are especially vulnerable to wind damage, as are manufactured homes.

### Nonstructural Protective Measures

To protect against wind damage without making any structural changes to a building, you can:

- Identify and remove trees and branches that could fall on the building walls or roof, or on power lines.
- Identify and repair loose or damaged building components such as siding, soffit and fascia, shingles and roofing, brickwork, and brick chimneys.

A hurricane brings torrential rain, and severe rainstorms may accompany a tornado. Buildings damaged by wind often suffer water damage as well. Water driven by hurricane-force wind can enter through usually rain-tight openings, and rain entering through a damaged roof can lay waste to the inside of a building.

Make sure that items such as important documents and irreplaceable personal objects such as photographs are stored in a safe location, preferably in watertight containers. Consider putting extra cash and important papers in a safe deposit box at your bank.

## Lesson 3. Protecting Against Wind Damage

### Nonstructural Protective Measures (Continued)

Hurricane warnings are issued about 24 hours before the hurricane is predicted to hit your area. If your area is under a hurricane warning:

- Move breakable items away from doors and windows.
- Board up doors and windows.
- Bring in outdoor furniture and other personal property kept outdoors.
- Secure manufactured home anchors.
- Secure outbuildings.
- Secure or move boats.
- Turn off propane tanks.

### Structural Protective Measures

The roof, doors, and windows of your house or place of business are potentially vulnerable to wind damage. When houses are exposed to hurricane forces, roofs are most susceptible to damage, followed by walls and openings.

**Roofs** can be protected from wind damage by:

- Ensuring that plywood roof sheathing is properly installed.
- Bracing roof trusses.
- Installing hurricane straps.

You can strengthen **doors and windows** by:

- Installing reinforcing bolt kits at the top and bottom of doors.
- Reinforcing garage doors.
- Installing storm shutters over windows.

This lesson will explain how you can protect your home or business from winds.

---

## Lesson 3. Protecting Against Wind Damage

### Protecting Roofs

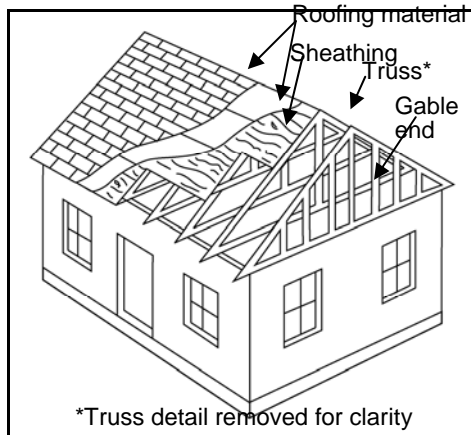

**Figure 2**

During a hurricane, wind forces are carried from the roof down to the exterior walls, down to the foundation. Homes can be damaged when wind forces are not properly transferred to the ground.

Figure 2 on the left shows the position of roof sheathing in the structure of a gabled roof. Roof sheathing (the boards or plywood nailed to the roof rafters or trusses) can fail during a hurricane if not properly installed. Examine the sheathing from the attic.

If many of the nails have missed the rafters, you may need to re nail the sheathing.

If you are replacing your roof, make sure the sheathing complies with current recommended practices.

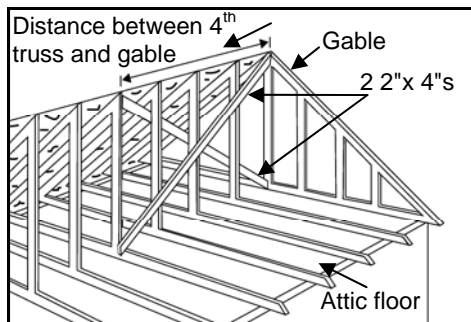

**Figure 3**

In a hurricane, the side walls of the roof (end gables) may take a real beating and collapse. Gable bracing often consists of 2"x 4"s placed in an "X" pattern at both ends of the attic: from the top center of the end gable to the bottom of the brace of the fourth truss, and from the bottom center of the end gable to the peak of the roof.

Figure 3 on the left shows gable bracing.

If your end gables do not appear to be braced, use a licensed contractor to install bracing. Ask your local building department whether a building permit is required for this work.

## Lesson 3. Protecting Against Wind Damage

### Protecting Roofs (Continued)

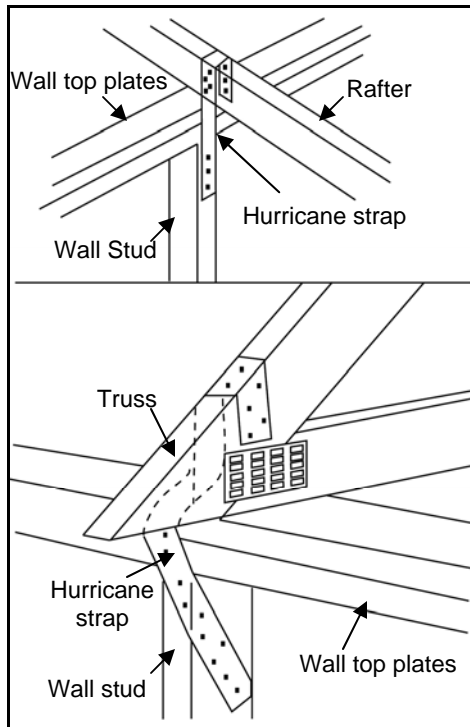

Hurricane straps (made out of galvanized metal) help keep the roof fastened to the walls in high winds. These straps are often difficult to install, so you may need a contractor for this project. Ask your building department whether hurricane straps are required or advisable in your area.

**Figure 4**

**Top: Placement of Hurricane Straps on Rafters**

**Bottom: Placement of Hurricane Straps on Trusses**

## Lesson 3. Protecting Against Wind Damage

### Protecting Doors

The exterior walls, doors, and windows are the protective shell of your home. If the shell is broken during a hurricane or tornado, high winds can enter the home and put pressure on the roof and walls, causing serious damage.

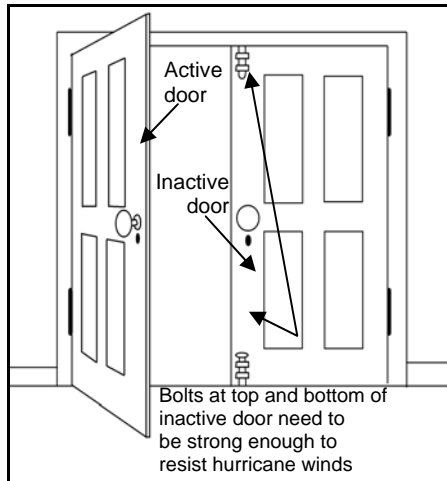

**Figure 5. Reinforcement of Double Doors Within a Home**

---

#### *Double-Entry Doors*

For each double door, at least one of the doors should be secured at both the top of the door frame and the floor with sturdy sliding bolts. Most bolts that come with double doors, however, are not strong enough to withstand high winds.

Your local hardware store can help you select the proper bolts. Some door manufacturers provide reinforcing bolt kits made specifically for their doors.

## Lesson 3. Protecting Against Wind Damage

### Protecting Doors: Garage Doors

If the garage door fails, winds can enter your home and blow out doors, windows, walls, and the roof.

Doublewide (two-car) garage doors can pose a problem during hurricanes because they are so large that they wobble as the high winds blow and can pull out of their tracks or collapse from wind pressure.

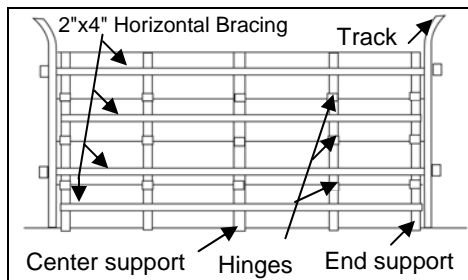

**Figure 6. Reinforcement of Double Garage Doors**

Some garage doors can be strengthened with retrofit kits. Many garage doors can be reinforced at their weakest points. Ask your building department for guidance on what to do.

Retrofitting your garage doors involves installing horizontal bracing onto each panel. This horizontal bracing may be available in a kit from the garage door manufacturer. You may also need heavier hinges and stronger center supports and end supports for your door.

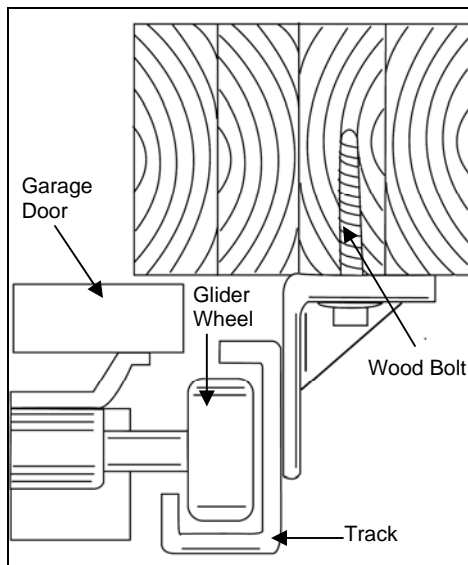

**Figure 7. Garage Door Reinforcement**

Check the track on your garage door. With both hands, grab a section of each track and see if it is loose or if it can be twisted. If so, a stronger track should be installed. Make sure that it is anchored to the 2"x 4"s inside the wall with heavy wood bolts or properly attached to masonry with expansion bolts.

## Lesson 3. Protecting Against Wind Damage

### Protecting Windows

Installing storm shutters is one of the best ways to protect your home or place of business from hurricane damage.

Purchase or make storm shutters for all exposed windows, glass surfaces, French doors, sliding glass doors, and skylights. There are many types of manufactured shutters made out of wood, steel, or aluminum. You can also make storm shutters with 5/8-inch thick exterior-grade plywood.

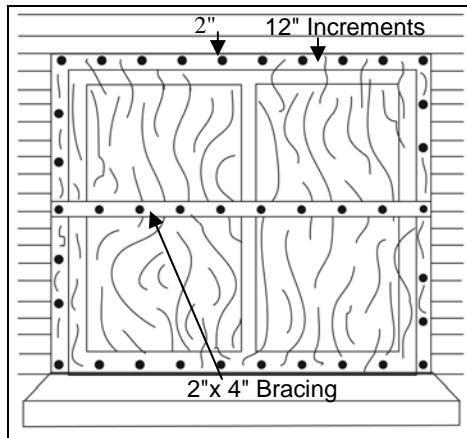

Plywood shutters that you make yourself, if installed properly, can offer a high level of protection from flying debris during a hurricane. Plywood shutters can be installed on all types of buildings.

Before installing shutters, check with your local building official to find out if a building permit is required.

**It is important that you have your shutters ready now, and that you mark and store them so they can be easily installed during a hurricane watch.**

**Figure 8. Two Methods for Installing Plywood Shutters**

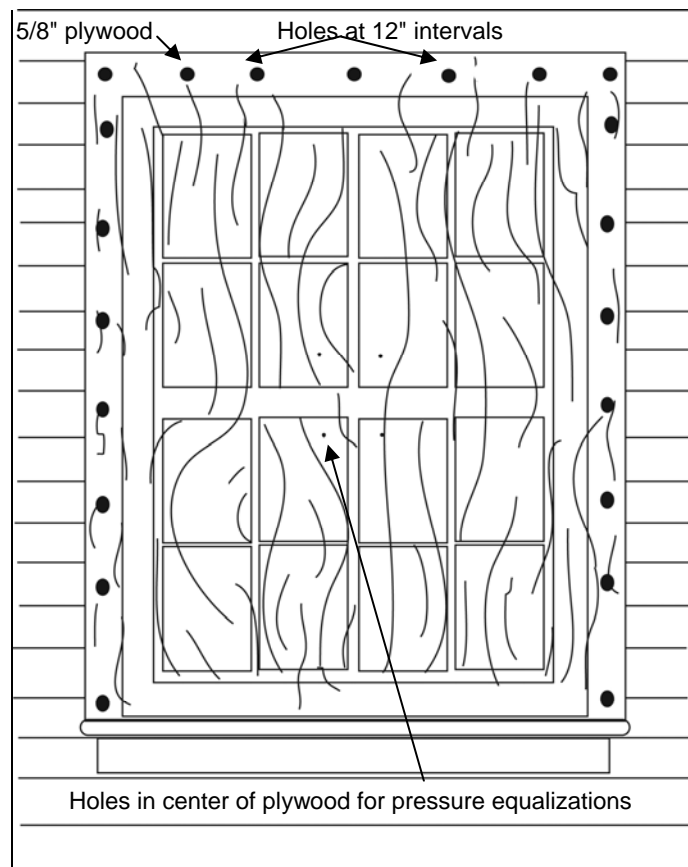



## Lesson 3. Protecting Against Wind Damage

### Tornado Risks

A tornado is a violent windstorm characterized by a twisting, funnel-shaped cloud. Tornadoes have been recorded in all 50 states, though they form most typically in a broad area of the American Midwest and South. The below map, "Tornado Risk Areas in the Continental United States," shows the relative risk of tornadoes.

#### Tornado Risk Areas in the Continental United States

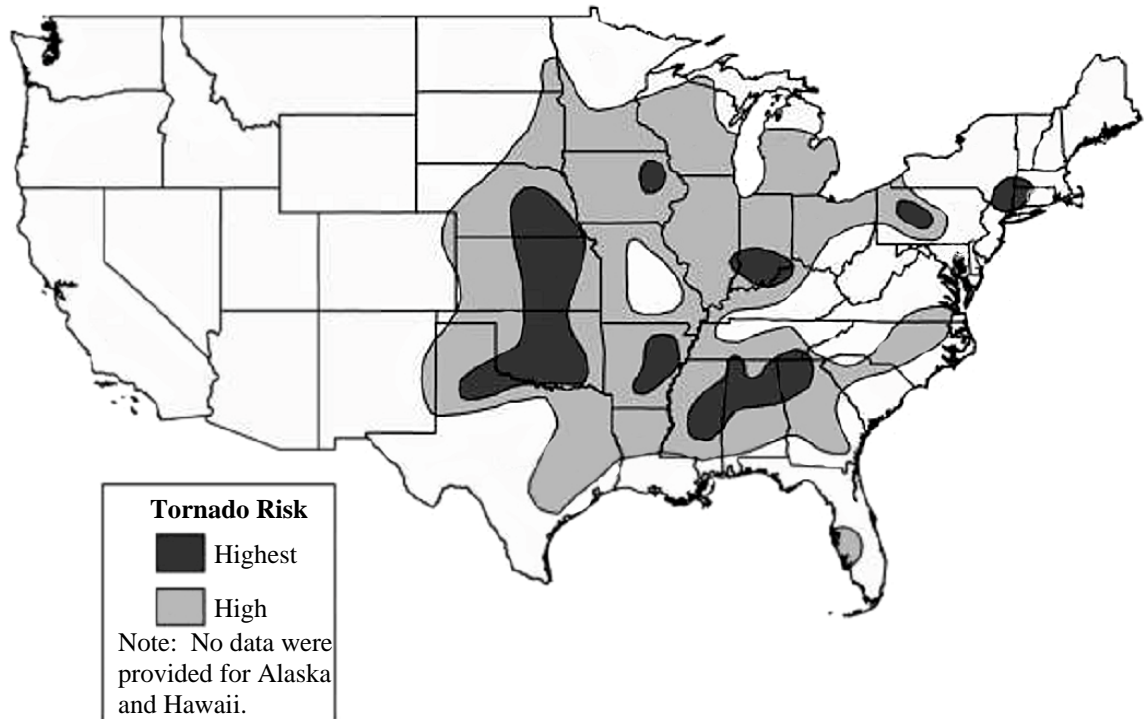

*ITS Mapping and Analysis Center  
Washington, DC*

*Source: United States Geological Survey*

**Figure 9. Map of the United States Showing Areas at Low, High, and Highest Risk of Tornadoes**

**Highest Risk States:** Portions of OK, AR, IA, IN, MS, AL, GA, PA, NY  
**High Risk States:** Portions of NE, KS, OK, TX, AR, MS, AL, TN, GA, SC, NC, KY, IN, IL, MO, IA, WI, MI, PA, FL

---

#### Self-Assessment Question:

Is your house or place of business located in an area of:

- Highest Risk       High Risk       Low Risk
-

## Lesson 3. Protecting Against Wind Damage

### Tornado Risks: Safe Rooms

When severe weather threatens, individuals and families community-wide need advance warning and protection from the dangerous forces of extreme winds. You may want to consider a safe room to protect you and your family from the high winds.

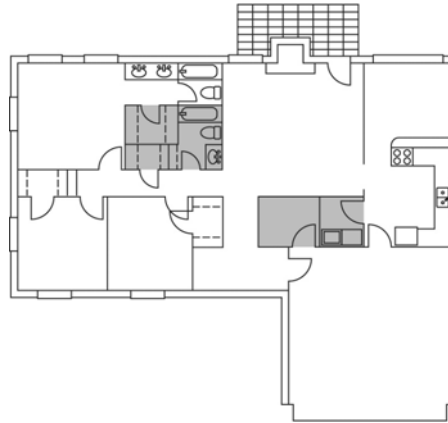

**Figure 10. Possible Safe Room Locations**

The purpose of a safe room or a wind shelter is to provide a space to seek refuge that provides a high level of protection. You can build a safe room in one of several places in your home or place of business:

- The basement.
- Atop a concrete slab-on-grade foundation or garage floor.
- An interior room on the first floor.

Safe rooms built below ground level provide the greatest protection, but a safe room built in a first-floor interior room also can provide the necessary protection. Below-ground safe rooms must be designed to avoid accumulating water during the heavy rains that often accompany severe windstorms.

To protect its occupants, a safe room must be built to withstand high winds and flying debris, even if the rest of the building is severely damaged or destroyed. Consider the following when building a safe room:

- The safe room must be adequately anchored to resist overturning and uplift.
- The walls, ceiling, and door of the shelter must withstand wind pressure and resist penetration by windborne objects and falling debris.

The connections between all parts of the safe room must be strong enough to resist the wind. Sections of either interior or exterior building walls that are used as walls of the safe room must be separated from the structure of the building so that damage to the building will not cause damage to the safe room.

## Lesson 3. Protecting Against Wind Damage

### Tornado Risks: Safe Rooms (Continued)

#### References

Specific guidance is available from FEMA on the construction of both residential safe rooms and community shelters.

- Taking Shelter From the Storm: Building a Safe Room Inside Your House. L-233.  
*Brochure providing details about obtaining information on how to build a wind-safe room to withstand tornado, hurricane, and other high winds.*
- Taking Shelter From the Storm: Building a Safe Room Inside Your House. FEMA-320.  
*Manual with detailed information about how to build a wind-safe room to withstand tornado, hurricane, and other high winds.*

Web link: <http://www.fema.gov/mit/saferoom/>

---

## Lesson 3. Protecting Against Wind Damage

### Protecting Your Place of Business

When a place of business is damaged, the business owner faces the cost to repair or replace the building(s). In addition, the business can suffer loss of inventory, business interruption, and loss of wages for employees.

Structural measures recommended to protect your place of business from wind damage are:

- Use threaded fasteners to attach metal roof decking. Welds are often unable to carry uplift loads.
  - In tornado-prone areas, use enhanced wind design for roof coverings on essential buildings.
  - Use adequate ties to foundations and roofs when reinforcing concrete and partially reinforced masonry.
  - Make ties between concrete and other materials with drilled-in fasteners or cast-in-place fasteners.
  - Engineer and construct masonry walls to support the specific architecture of the building (i.e., exterior wall panels, parapets, and decorative finishes). Diaphragm action to resist wind-generated shear forces must be maintained and reinforcement must be properly placed in concrete and masonry walls to reduce the possibility of collapse during high wind storms.
  - Use anchors in precast concrete buildings to prevent the uplift of hollow core planks and other precast elements during high winds.
  - Avoid the use of powder-driven anchors to attach bottom plates of walls to concrete unless the anchors are very closely spaced to resist pull-out.
  - Minimize the creation of windborne debris by appropriately designing, manufacturing, and installing architectural features.
-

## Lesson 3. Protecting Against Wind Damage

### Success Stories

To read more about Success Stories, go to [New Success Story Site](#).

#### **Moore, Oklahoma**

---

Don Staley and his family are no strangers to storms and tornadoes. Their first home was hit by a tornado in October 1998 and suffered minor damage but was destroyed by another tornado on May 3, 1999. They rode out both storms inside the house. "It was such a frightening sound," he said. "We decided we weren't going to ride out another one inside the house."

In December 2000, the Staley's new home was ready. Shortly after moving in, they had an above-ground safe room constructed on the back patio. The concrete room has 8-inch thick walls, an 18-inch thick ceiling, a 10-inch foundation, and a sliding entry door made of 12-gauge steel with three-quarter inch plywood on each side. The safe room is equipped with battery-powered lights and a battery-powered television.

When the warning sirens sounded on May 8, 2003, Don took shelter in the safe room along with his dog and two cats to ride out the storm feeling very protected and safe. "I was watching it on TV in there," he recalled. "I could see it was coming my way and I could hear it coming. I could hear the roar. That's a sound you never forget."

When he emerged from the shelter, he found his house in shambles with the roof ripped off. Other houses on the street were also heavily damaged or destroyed. The Staleys used their safe room following the tornado to store and protect belongings they had salvaged.

The Staley's home was among the more than 300 homes destroyed in the city that day. Whereas a severe tornado that hit the city in May of 1999 claimed 44 lives, there were no deaths in the 2003 tornado. The absence of fatalities is being attributed to community preparedness, improved early warning systems, and the many safe rooms and shelters that have been built.

Staley sums it all up, "The safe room saved my life, it came through with flying colors. It's worth a million bucks to me."

---

### Success Stories

#### Charlotte Harbor, Florida

---

Hurricane Charley came to Charlotte Harbor one Friday, with winds up to 114 mph, leaving the community stunned. Buildings were destroyed, and streets were filled with debris and downed power lines. While the storm was swirling through town, 30 newspaper employees braved the storm at their office unable to get home. They were dry and secure because the structure was built to resist strong winds and the windows were fitted with storm shutters.

In the mid-1990s, Richard Hackney, Vice President of Operations, lobbied the stockholders for storm shutters to protect the *Sun* newspaper building in Charlotte Harbor. His experience with Hurricane Andrew taught him that an investment would be worth it. The shareholders agreed, and the shutters were purchased for \$15,000.

When installed, storm shutters maintain building integrity by protecting the windows from direct wind pressure and windborne debris. If flying debris breached large office windows, wind-driven rain could enter and cause the loss of valuable computers containing information on news stories, research, subscribers, and other files. Intense winds coming in through these windows would cause “uplift” pressure on the roof system. Pressure inside the building, along with the speed of the wind above the roof surface, could lift the roof causing catastrophic damage to the building, its contents, and anyone working inside.

According to David Dunn-Rankin, President of the *Sun*, “The shutters helped keep the roof on and kept us operational. If we had lost the roof...I don’t know...it’s frightening. Lost revenue, subscriber credits, computer replacement, press equipment repairs or replacement, and production outsourcing all add up. We could have been looking at \$3 million to get us back to where we could put out the paper here.”

The entire Charlotte Harbor area was without power, but even that did not stop the *Sun* from publishing. The paper was without power for 14 days. However, because the building integrity had been maintained, they were otherwise operational. Instead of shutting down, they hooked up a rented, 1750KV generator, and published the newspaper.

“We didn’t miss a beat,” said Dunn-Rankin.

“It’s not just about the dollars, it’s about publishing.” said Hackney. “It’s not even an option not to publish. We have to be able to protect our people, our building, our presses, and maintain our capacity to publish. We met our goal.”

The *Sun* came out on the Monday following Charley’s hit on Friday.

---

## Lesson 3. Protecting Against Wind Damage

### Summary: Key Steps To Protect Against Wind Damage

This lesson reviewed the following steps you can take to protect your home or business against wind damage.

- Know your risk of wind damage. Certain areas have a high risk of damage from hurricanes, tornadoes, or high winds.
- Remove overhanging and dead tree limbs that could fall on buildings or power lines.
- Repair loose or damaged building components such as siding and roof shingles.
- Place important possessions and valuables in safe locations.
- Secure:
  - Manufactured home anchors.
  - Outbuildings.
  - Boats.
- Move breakable items away from doors and windows. Board up doors and windows.
- Bring in outdoor furniture and other personal property kept outdoors.
- Turn off propane tanks.
- Make structural changes, including:
  - Bracing and strapping the roof.
  - Making doors and garage doors more wind-resistant.
  - Installing storm shutters on windows.
- Consider building a safe room to protect against tornadoes.
- As you construct or modify your place of business, design for wind resistance by incorporating recommended fasteners, ties, reinforcements, and anchors.

The protective measures you consider depend on where your house or business is located.

Is your location vulnerable to hurricanes, or at high risk of tornadoes? If so, decide which protective measures make the most sense in your situation.

- Take appropriate nonstructural protective measures.
- Consider whether retrofitting and/or building a safe room would be advisable.

## Lesson 3. Protecting Against Wind Damage

### Test Yourself

The questions below review key points in protecting against wind damage. After completing the questions, you can check your answers on the answer sheet located after the course glossary.

1. Hurricanes can be predicted, so you have 2 to 3 days to prepare, but \_\_\_\_\_ strike with little warning.
2. Mark any of the following structures that are especially susceptible to wind damage.
  - Brick houses
  - One- and two-story wood-frame houses
  - Manufactured homes
  - Steel-frame commercial buildings
3. Write below three protective, **nonstructural** measures you can take in the 24 hours before a hurricane is predicted to hit your area.  
\_\_\_\_\_  
\_\_\_\_\_  
\_\_\_\_\_
4. Select the protective measure on the right that would be used to protect the structure on the left, and write the appropriate letter on each blank space.

___ Roof	a. Secure with sliding bolts
___ Double-entry doors	b. Install horizontal bracing
___ Garage door	c. Install hurricane straps
___ Window	d. Buy or make storm shutters
5. Safe rooms built below ground level provide the greatest protection.  
\_\_\_\_\_ True                      \_\_\_\_\_ False